

EXPLODED VIEW & PARTS LISTING

Model: DP-50BPT-HD (XDP)



Part#: 854470

Air Operated Double Diaphragm Pump

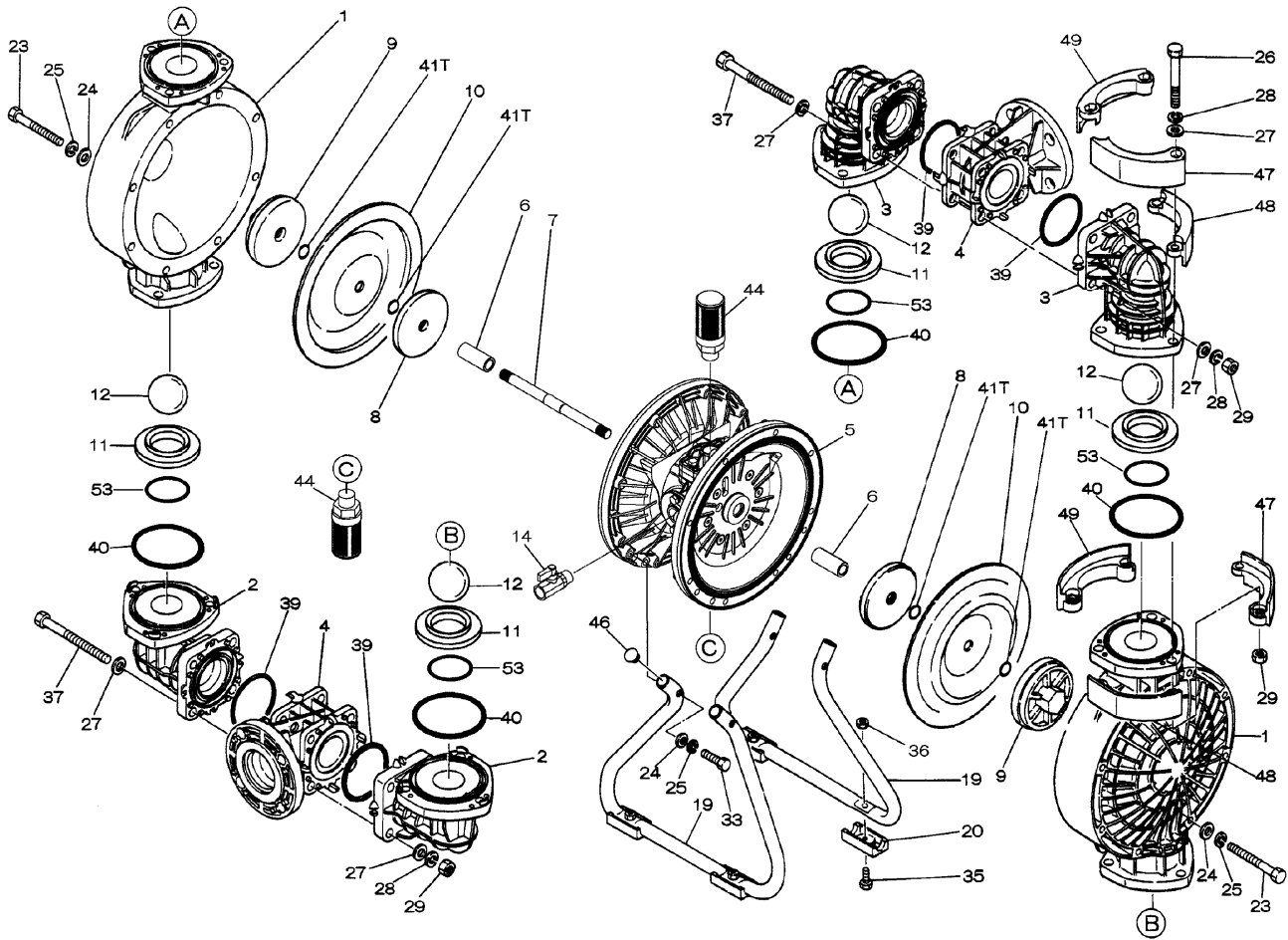

Air Operated Double Diaphragm Pump

804853 Center Body Assembly

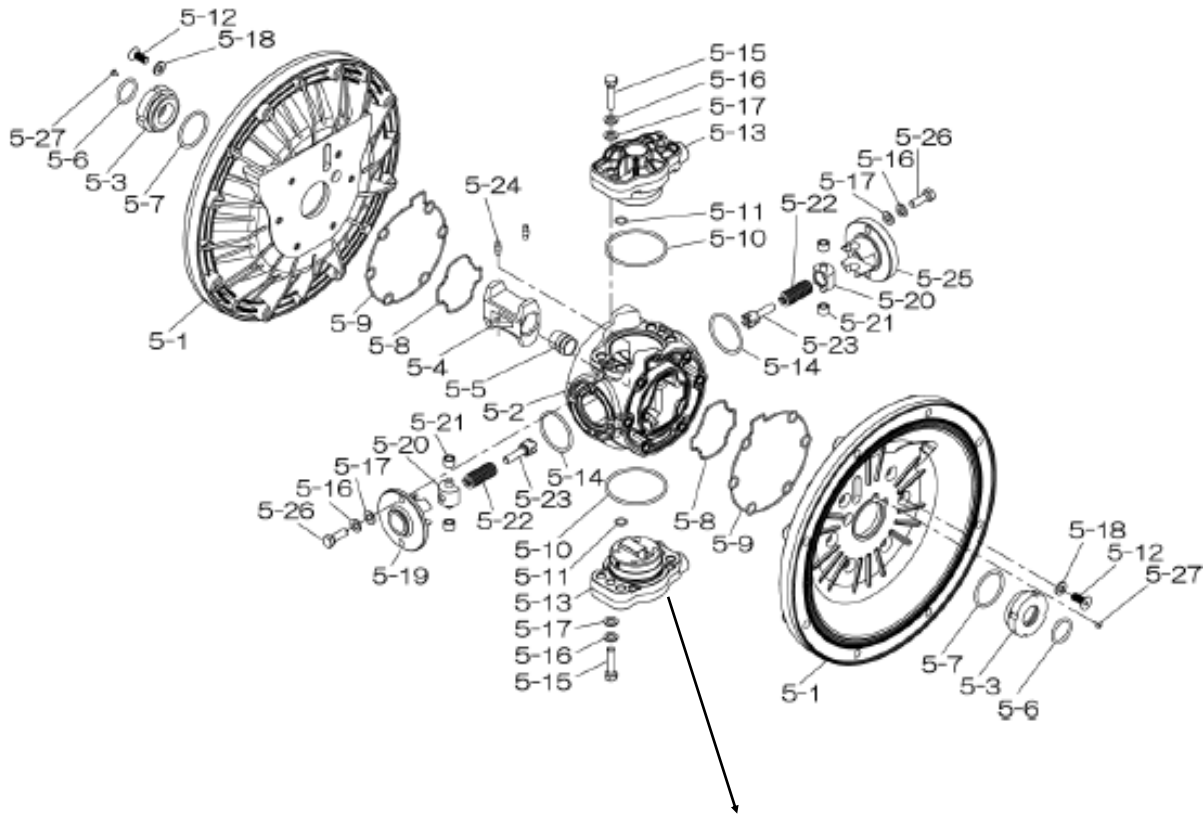

804784 Valve Body Assembly

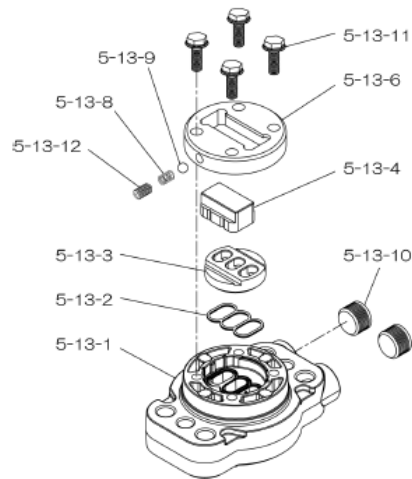

Air Operated Double Diaphragm Pump

REF. NO.	PART NO.	DESCRIPTION	QTY.	REORDER
1	780148	OUT CHAMBER	2	
2	780245	IN MANIFOLD	2	
3	780151	OUT MANIFOLD	2	
4	780249	CENTER MANIFOLD	2	
5	804853	CENTER BODY ASSY	1	
5-1	716247	AIR CHAMBER	2	
5-2	716256	BODY	1	
5-3	773095	THROAT BEARING	2	
5-4	716214	SHUTTLE	1	
5-5	773047	CENTER ROD GUIDE	1	
5-6	640023	O RING	2	
5-7	640133	O RING	2	
5-8	773040	GASKET	2	
5-9	773041	GASKET	2	
5-10	640138	O RING	2	
5-11	640007	O RING	8	
5-12	683812	FLAT SOCKET	12	
5-13	804784	VALVE BODY ASSY	2	
5-13-1	715244	VALVE BODY	1	
5-13-2	773042	GASKET	1	
5-13-3	716246	SEAT	1	
5-13-4	773425	BLOCK	1	
5-13-6	773426	GUIDE PLATE	1	
5-13-8	706612	SPRING	1	
5-13-9	686271	BALL	1	
5-13-10	772934	PLUG	2	
5-13-11	602300	TAPPING BOLT	4	
5-13-12	610025	HEX. SOCKET HEAD SCREW	1	
5-14	640134	O RING	2	
5-15	611153	BOLT	4	
5-16	631420	SPRING WASHER	8	
5-17	631013	WASHER FLAT	8	
5-18	684987	WASHER	12	
5-19	716249	RETAINER	1	
5-20	713620	SPRING GUIDE	2	
5-21	773067	BUSH	4	
5-22	684537	SPRING	2	
5-23	714446	TRIP ARM	2	
5-24	700231	PIN	2	
5-25	716216	RETAINER	1	
5-26	611149	BOLT	4	
5-27	686337	TAPPING SCREW	2	

REF. NO.	PART NO.	DESCRIPTION	QTY.	REORDER
6	716399	CENTER BUSH	2	
7	716404	CENTER ROD	1	
8	711904	CENTER DISK	2	
9	771727	CENTER DISK	2	
10	770815	DIAPHRAGM	2	
11	772097	VALVE SEAT	4	
12	770693	BALL	4	
14	686974	BALL VALVE	1	
19	711926	STAND SOPP	2	
20	771865	FOOT RUBBER	4	
23	686156	BOLT	16	
24	631330	WASHER FLAT	24	
25	680257	SPRING WASHER	24	
26	621213	BOLT	12	
27	631331	WASHER	28	
28	680607	SPRING WASHER	20	
29	628014	NUT	20	
33	621179	BOLT	8	
35	621149	BOLT	4	
36	683837	NUT W/FLANGE	4	
37	684592	BOLT	8	
39	643064	O RING	4	
40	643069	O RING	4	
41T	643015	O RING	4	
44	804697	MUFFLER	2	
46	683641	CAP	4	
47	771786	PROTECTOR A	8	
48	771787	PROTECTOR B	8	
49	771788	PROTECTOR C	8	
53	643139	O RING	4	
KIT	K50-PT	LIQUID SIDE KIT		
KIT	K45-AM-DP-HD	AIR MOTOR KIT		

Torque Requirements:

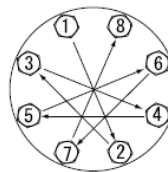

Tightening torque for center rod and out chambers.
Center Rod 36 ft-lbf {50 N-m}
Out Chambers 26 ft-lbf {35 N-m}

Tightening torque for manifold retainer bolts.
BPT 18 ft-lbf {25 N-m}

General Tools:

- Socket wrench - 13mm, 17mm, 19mm
- Hexagonal box wrench - 5mm, 6mm
- Phillips head screw driver

Special Tools:

- PP wrench (771868) for removing the center disk
- Socket (804129) for a guide to remove the throat bearing (sold separately)

Miscellaneous:

- Assembly Oil - Turbine oil none additional class 1 (equivalent to ISO VG32 grade)
- Nuts - M16 x 1.5
- Thread locker
- Urea grease grade (NLGI) No. 2, Shell Alvania Grease S1

Customer Notes

Model #: _____
Description: _____
Serial #: _____
Date Installed: _____
Department Location: _____
Tag/Project: _____